

Heat Sealer

HEAT SEALER – MODEL PDSL

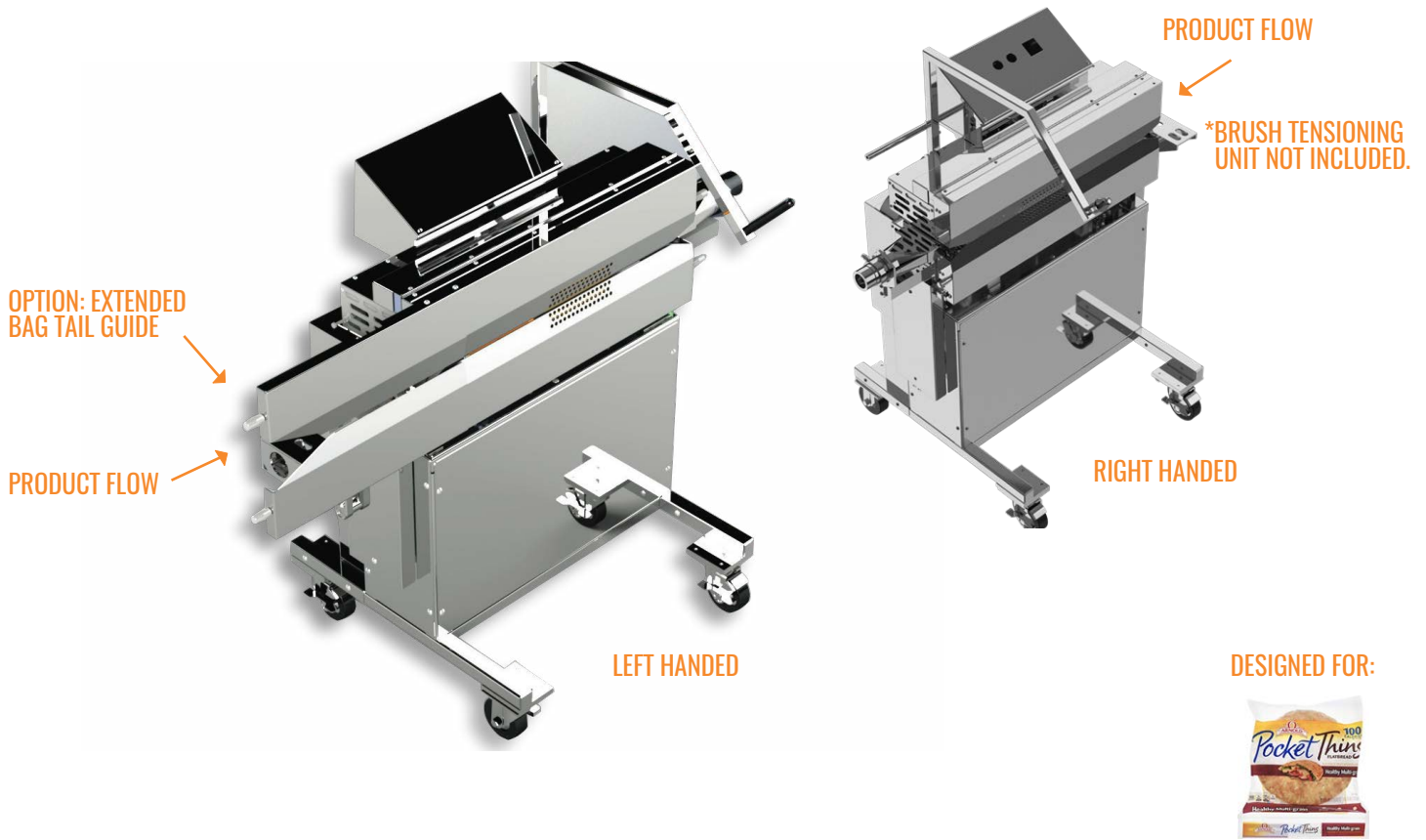

LMC's heat sealer seals plastics, packaging, and other thermoplastic materials using heat. The PDSL heat sealer can be easily integrated into your existing line. This model can tackle up to 70 packages per minute.

TECHNICAL SPECIFICATIONS

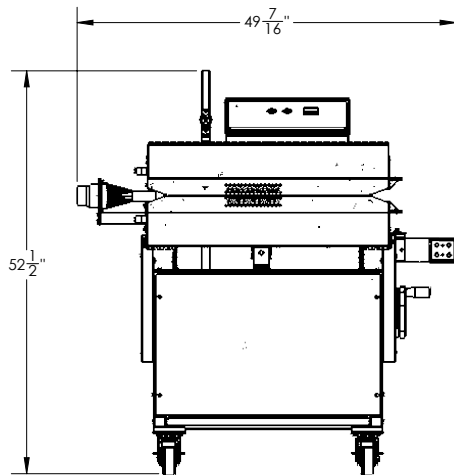
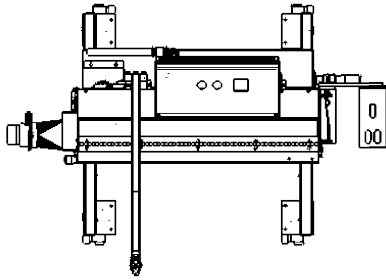

ELECTRICAL	230/460 VAC, 20 AMP, three phase (60hz), Includes 120v transformer
SAFETY	Stainless steel fully hinged guards allow complete access for trim removal
SPEED	Variable speed, up to 120 feet per minute
AIR REQUIREMENTS	Dry filtered one drop (12 CFM maximum @ 100 psi)
SEALER HEIGHT	33 1/2" to 40 1/2" - 28 1/2" to 35 1/2"

KEY FEATURES

- » Speed of 10 to 70 packages per minute
- » Belt speed up to 120 feet per minute
- » Produces a 3/16" wide seal
- » Disc blade to trim excess bag materials
- » Pivot head and open guarding allows for easy maintenance
- » Trim removal vacuum system

Specifications vary by product and application. Please contact our sales office about product varieties and speeds.

OPTIONS

- » Stainless steel frame
- » Trim removal vacuum system
- » Tall or short units
- » Sealer height:
 - » Tall: 33 1/2" to 40 1/2"
 - » Short: 28 1/2" to 35 1/2"
- » Conveyor height:
 - » Tall: 32 1/8" to 36 1/2"
 - » Short: 28 1/2" to 32 1/2"
- » Extended Bag Tail Guide



WATCH A VIDEO OF OUR SEALER SEALING BAGS